

WELDEX

Moderate, welding fume extraction unit.

PUREX

CLEAN AIR FOR EVERYONE



Description & features

- Clear & informative graphic display
- Highest grade HEPA and carbon technology
- Adjustable airflow
- Large dust holding capacity

Filters



Main Filter Code

113505C

Description

HEPA/Chemical



Pre-Filter Code

111097

Description

F8 / F9 Labyrinth

Specification

Voltage	90v - 235v
Part Number	WEL400
Wattage	1.1kW
Frequency	50Hz / 60Hz
Cabinet Height (Not Including Arm)	995mm
Cabinet Width (Not Including Arm)	470mm
Cabinet Depth (Not Including Arm)	465mm
Cabinet Weight (Not Including Arm)	60kg
Airflow	400m ³ /h
Sound Level	<60dBa

Machine supplied with

- 1 x Main Filter • 1 x Pre-Filter • 1 x Power Cable • 1 x Manual

Find out more: W.purex.co.uk | [T +44 \(0\)1405 746030](tel:+44(0)1405746030) | [E purex@purex.co.uk](mailto:purex@purex.co.uk)

Registered Office: Purex International LTD, Unit A, Saltgrounds Road, Brough, HU15 1EG, UK

Registered No. 5136616 England | VAT No. GB842 5025 49 | WEEE Producer Registration Number: WEE/CE0067TX

*Goods are subject to change | *Illustrations are 3D created visual representations

WELDEX

Moderate, welding fume extraction unit.

Options

Mobile Extraction Arm

Included (Oskar Arm)

The machine is high in mobility due to it's castors and the 75mm multi position arm; meaning the machine can be moved from station to station as and when required. The arm has a working area of up to nearly 2m.

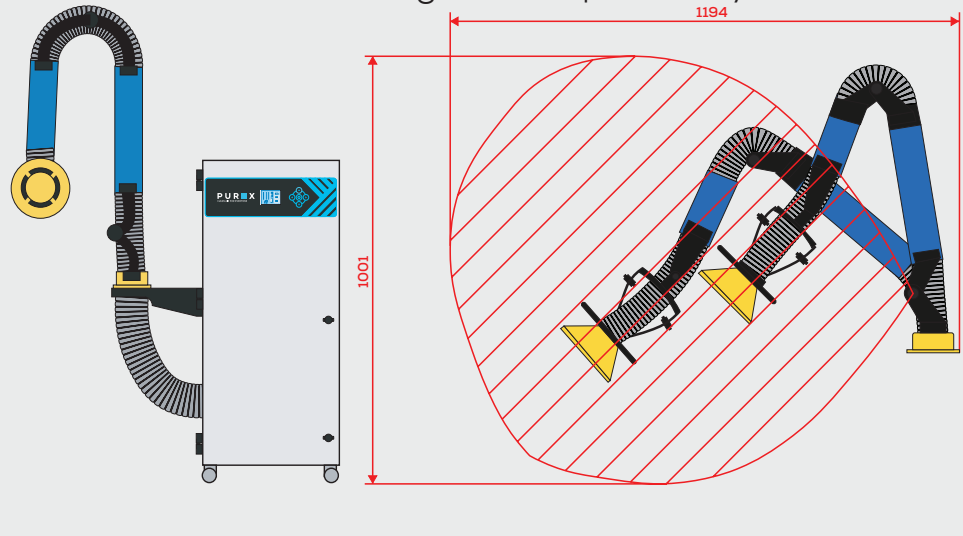

Interfacing

Interfacing can remotely start the Purex machine when the connected machine starts.

Interfacing can also warn the connected machine when the Purex machine is in alarm.

Your Machine

10011010



Extractor

10011010

Take a look through our [Interfacing Guide](#) to see our extensive range of options